

DECONTAMINATION OF ESCO CLASS II BIOSAFETY CABINET USING VAPORIZED HYDROGEN PEROXIDE

by
XQ Lin, Alexander Atmadi, Olga Nelson | Esco Technologies, Inc. USA

The Need for Decontamination

Biological safety cabinets should be decontaminated under the following conditions:

1. Accessing the contaminated plenum, to change the filters, blowers, etc.
2. Relocation of the cabinet from one room / building to another
3. When the type of micro-organisms is drastically changed
4. After a serious spill of a dangerous micro-organism
5. When there is product contamination contributed to the cabinet
6. Periodically, especially if BSL-3 or BSL-4 organisms are being manipulated inside the cabinet

Formalin / Paraformaldehyde Decontamination

Typically the decontamination is performed using formalin gas by either vaporizing 37% formalin solution or by depolymerization of solid paraformaldehyde, with concentration of > 8000 ppm.

Despite its widespread usage for decontamination, formalin presents the following health risks:

1. External contact can cause irritation to skin, eyes, and mucous membranes.
2. Inhalation in small concentrations can cause coughing, nausea, and diarrhea.
3. Inhalation in large concentrations can cause convulsions, coma, and death.
4. Long term exposure can cause cancer.

Although the Permissible Exposure Level (PEL) for formalin is 0.75 ppm, many scientists believe that there is no safe level of carcinogen exposure to humans. Therefore, typically the room must be evacuated when the decontamination process is performed, which leads to lab down time.

The use of formalin decontamination also has other disadvantages:

1. The process is time-consuming.
2. The certifier needs to pulse the cabinet fan to circulate the formalin vapour. This can dislodge the tape holding the plastic sheet covering the exhaust filter.
3. Due to excessive residue extensive cleaning must be done after decontamination and before use.

The formalin decontamination process can require an extended period of time as outlined below:

#	Process	Time
1	Set-up & sealing the cabinet to make it air tight	1 hour
2	Formalin vaporization	½ hour
3	Formalin contact time to obtain target log of 4-6 kill	8 – 10 hours
4	Ammonia vaporization to neutralize formalin	½ hour
5	Ammonia contact time to neutralize formalin	2 hours
6	Exhausting the ammonia residue	1 hour
7	Tear-down & cleaning the (substantial) residue	1 hour
	TOTAL without ammonia neutralization	10 ½ – 12 ½ hours
	TOTAL with ammonia neutralization	14 – 17 hours

Due to the adverse health effect of formalin gas, its use has been banned in Germany, Austria, and Switzerland. Other European countries are expected to follow suit. Two primary candidates to replace formalin decontamination are chlorine dioxide gas and hydrogen peroxide vapor.

Chlorine Dioxide Decontamination

Chlorine dioxide decontamination is performed by injecting chlorine gas (Cl₂) into a cylinder filled with solid sodium chlorite (NaClO₂), which generates the greenish-yellow chloride dioxide gas (ClO₂).

Chlorine dioxide decontamination is much faster than formalin. Being a true gas, it spreads quickly, without the need of pulsing the cabinet’s blower. It can rapidly kill the micro-organisms with high efficacy with just 1 hour contact time. There is minimal residue to clean after the decontamination making the entire process much faster than formalin decontamination. The time required for the entire process of ClO₂ decontamination is as follows:

#	Process	Time
1	Set-up & sealing the cabinet to make it air tight	1 hour
2	Chlorine dioxide gassing	½ hour
3	Chlorine dioxide contact time	1 hour
4	Chlorine dioxide “scrubbing”	½ hour
5	Tear-down & cleaning the (minimal) residue	½ hour
	TOTAL	3 ½ hours

Chlorine dioxide has the Permissible Exposure Level (PEL) of 0.1 ppm, compared to 0.75 ppm for formalin. In both processes airtight cabinet sealing is required to protect personnel from the gas exposure.

D. Hydrogen Peroxide Decontamination

Hydrogen peroxide (H₂O₂) decontamination is performed by flash vaporization of an aqueous peroxide mixture, creating a vapor that is distributed throughout the inside the Biosafety cabinet.

Steris and Bioquell are two major vendors of hydrogen peroxide generators. There are significant differences in operating principles.

The Steris principle is to avoid condensation on surfaces to minimize corrosion and optimize vapor distribution. The relative humidity inside the cabinet must be lowered to 30% so that the remaining 70% relative humidity can be occupied by the hydrogen peroxide vapor.

The Bioquell principle is to seek micro-condensation to achieve the kill. The generator releases high-speed droplets inside the cabinet.

Hydrogen peroxide vapor is non-carcinogenic, but highly effective against micro-organisms. Hydrogen peroxide (H₂O₂) vapor breaks down under catalytic action to become air and water, making it environmentally friendly and it leaves no residues. The decontamination process is as fast as chlorine dioxide if the cabinet is ducted. However, if the cabinet is not ducted, the hydrogen peroxide must be aerated, which is time-consuming.

The time needed for the entire process is outlined below:

#	Process	Time
1	Set-up & sealing the cabinet to make it semi-airtight	½ hour
2	Conditioning and decontamination cycle	1 ½ hour
3	Ducting out H ₂ O ₂ H ₂ O ₂ generator doing aeration	½ hour 8 hours
4	Tear-down	½ hour
	TOTAL	3 hours 10 hours

For hydrogen peroxide decontamination, the biosafety cabinets need to be equipped with two ports:

1. One port located in front opening or side wall, penetrating the work zone area
2. One port located on top of the exhaust filter. This is not needed if the cabinet is ducted

The generator used defines the port function as described below:

	Steris	Bioquell
Hydrogen peroxide source	Injected into the cabinet	Generated inside the cabinet
Bottom front / side port	Hydrogen peroxide introduction	Hydrogen peroxide re-introduction
Top port	Hydrogen peroxide extraction	Hydrogen peroxide extraction

No	Aspect	Formalin Vapor	Chlorine Dioxide	Hydrogen Peroxide
1	Is it carcinogenic ?	Yes	No	No
2	Is it a genotoxin ?	Yes	No	No
3	Permissible Exposure Level (PEL)	0.75 ppm	0.1 ppm	1 ppm
4	Immediately Damaging to Life & Health (IDLH)	2 ppm	5 ppm	75 ppm
5	Sealing of the biosafety cabinet	Must be airtight	Must be airtight	Some small gaps are OK
6	Must people leave lab during the process ?	Yes, due to leakage danger	Yes, due to leakage danger	No, people can still work in lab
7	Is room humidity control required ?	Yes, above 60%	Yes, between 60 to 80 %	No
8	Residue	Substantial, needs extensive cleaning	Minimal, in the form of NaCl	No residue
9	Decontamination time per cabinet	11-17 hours	3-4 hours	3-10 hours
10	Equipment cost	USD \$100	USD \$1,500 + Cl gas canister	USD \$18,000 to \$52,000

Some people may argue that hydrogen peroxide vapor, being a non-true gas, may not reach and decontaminate all the corners inside the biosafety cabinet. They are also concerned that hydrogen peroxide being a strong oxidizer, may corrode various metals or components used in the cabinet. To determine if these concerns were valid the following experiment was conducted.

Validating Hydrogen Peroxide Decontamination Efficacy on ESCO Class II Biosafety Cabinet

To validate the hydrogen peroxide effectiveness on ESCO Biosafety cabinet, an experiment was conducted using one of the largest Esco cabinets, an Esco Labculture Class II Type A2 – 6ft cabinet (LA2-6A2). The test was performed at ESCO Technologies Inc. facilities in Hatboro, Pennsylvania, USA.

A Steris VHP-1000 ARD was used as the hydrogen peroxide generator. To validate the decontamination efficacy, Steris Spordex Biological Indicator (BI) containing *geobacillus stearothermophilus* spores, which is one of the most hard-to-kill spores, and Steris NB305 Chemical Indicators (CI) were placed at 8 locations as shown below:

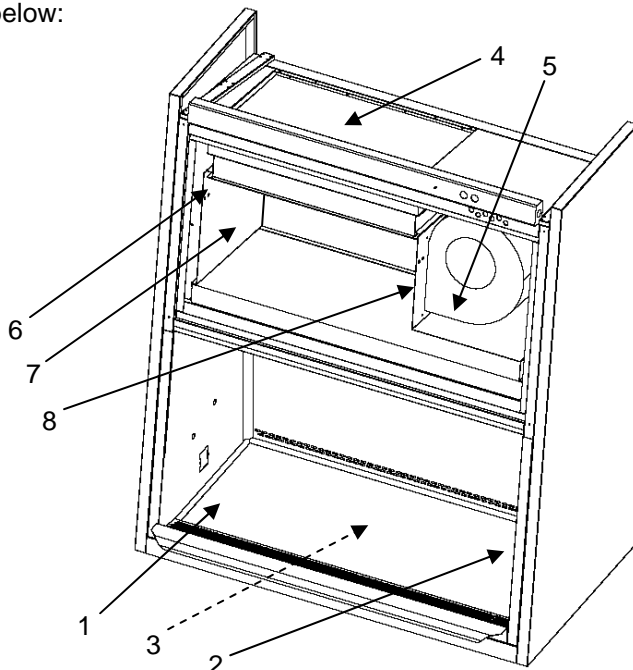

No	BI and CI Location
1	Work Tray: front left
2	Work Tray: back right
3	Drain pan (under the work tray)
4	Above exhaust filter
5	Negative plenum: beside blower
6	Negative plenum: front left corner
7	Positive plenum: front left corner
8	Positive plenum: right corner

To investigate the material compatibility of the entire cabinet with hydrogen peroxide, a large plastic bag was used to enclose and expose the entire cabinet to the vapor. Pictures of the cabinet's critical components, such as blower, electrical panel, microprocessor main board, LCD display, and control touchpad were taken before and after the decontamination.

Below are pictures showing the set-up, with the cabinet completely enclosed inside a plastic bag which is then taped to the floor. The Steris VHP-1000 ARD generator is placed outside the cabinet and connected to the front and top ports. The hydrogen peroxide is injected at the front aperture of the cabinet, and extracted from above the exhaust filter:



Below is the table describing the time span and parameters used to validate the decontamination process:

No	Process	Time	Airflow (SCFM)	Injection Rate (g/m)
1	Dehumidification	15 min	20	-
2	Conditioning	4 min	17	6.0
3	Decontamination	45 min	17	3.5
4	Aeration	8 hr 0 min	20	-

Note: The cabinet was not ducted outside and required an 8 hour aeration process. For ducted cabinets, such as Class II Type B2 or Class II Type A2 with the exhaust transition sealed, the hydrogen peroxide vapor can simply be exhausted outside via the duct.

After the aeration process was finished, the plastic bag tape on the floor was opened slightly and a Dräger gas detection kit was used to measure the hydrogen peroxide concentration. Once the concentration is below 1ppm, the plastic bag can be opened, and the BIs/CIs removed.

To investigate consistency of this process and the material resistance to repeated hydrogen peroxide exposure three tests were performed. The eight Chemical Indicators from each of the three tests change in color from blue to grey. This indicates all 24 Chemical Indicators of the three tests were exposed to hydrogen peroxide. The strips from one test, indicative of all three tests, are shown in the photo below:



- This is the control tab, with original blue color.
- This the test tab. They all changed color from blue to grey, indicating complete H₂O₂ exposure.

This positive result from all the CIs proved that the hydrogen peroxide did penetrate all areas of the cabinet; debunking the belief that hydrogen peroxide cannot reach all parts of the cabinet because it is not a true gas.

The *geobacillus stearothermophilus* spore strips were sent to Raven Labs, an independent microbiological test lab in Nebraska, USA. At Raven Labs, the spore strips were transferred into test tubes containing tryptic soya broth, and incubated at 60°C for 7 days. Below are the results after 7 days of incubation:

No	Spore Strip Location	1 st Trial	2 nd Trial	3 rd Trial
1	Work Tray: front left	No growth	No growth	No growth
2	Work Tray: back right	No growth	No growth	No growth
3	Drain pan	No growth	No growth	No growth
4	Above exhaust filter	No growth	No growth	No growth
5	Negative plenum: beside blower	No growth	No growth	No growth
6	Negative plenum: front left corner	No growth	No growth	No growth
7	Positive plenum: front left corner	No growth	No growth	No growth
8	Positive plenum: right corner	No growth	No growth	No growth
X	Control	1.4x10 ⁶ CFU	1.4x10 ⁶ CFU	1.4x10 ⁶ CFU

This indicates that the hydrogen peroxide vapor reached all areas of the cabinet and effectively neutralized the hard-to-kill micro-organisms.

In addition to the excellent results from the BI and CI strips, there was no material degradation of the cabinet or controls observed after the three trials. The cabinet operated the same after three cycles of hydrogen peroxide decontamination as it did before the tests. This indicates that the materials used on Esco biological safety cabinets are compatible with hydrogen peroxide.

Extensive visual and physical evaluation was performed on all critical components including the blower, electrical components, microprocessor, LCD display and key pad. There was no degradation of any component of the ESCO Biosafety cabinet.

Conclusions:

The Steris VHP-1000 ARD hydrogen peroxide generator is an effective decontamination instrument for ESCO Biosafety cabinets.

Esco Biosafety cabinets are compatible with hydrogen peroxide vapor.

In summary this translates to a safer process for the user, field certifiers, and the cabinet itself.

Literature References

Luftman, H. (2005). *Decontamination – Alternative Techniques* [PowerPoint slides].

Pitt, Graham (2004). Assessment of the Efficacy of the BIOQUELL EBDS Vapour Phase Hydrogen Peroxide System to Disinfect a Class II Safety Cabinet. p.2-12. HPA PD Report 882-03.

NSF International (2002). Annex G – Recommended microbiological decontamination procedure, *NSF International: Standard No. 49 for Class II (Laminar Flow) Biohazard Cabinetry, G1-G3*.

New Jersey Department of Health (2005). Hazardous Substance Fact Sheet: Formaldehyde. Retrieved 18th October 2008 from: <http://www.state.nj.us/health/eoh/rtkweb/documents/fs/0946.pdf>

New Jersey Department of Health (2005). Hazardous Substance Fact Sheet: Chlorine Dioxide. Retrieved 18th October 2008 from: <http://nj.gov/health/eoh/rtkweb/documents/fs/0368.pdf>

Jeng, D.K. and Woodworth, A.G. (1990). Chlorine dioxide gas sterilization under square-wave conditions. *Applied and Environmental Microbiology*, Vol. 56 No.2, 514-519.

Hillman, D. (2004). Vapor phase hydrogen peroxide gas decontamination of a BSC. *Performance Review*, 10, 10-16



WORLD CLASS. WORLDWIDE.

Biotechnology Equipment Division
Fume Filtration Division
Laboratory Fume Hoods Division
Performance™ Cleanroom Apparel Division
Cleanroom Equipment Division

Worldwide Headquarters • Esco Micro Pte Ltd • 21 Changi South Street 1 • Singapore 486777
Phone +65 65420833 • Fax +65 64526920 • mail@escoglobal.com • www.escoglobal.com

ROC No. 198400165W

OSHA (1996). Substance technical guidelines for formalin. Retrieved 18th October 2008 from: http://www.osha.gov/pls/oshaweb/owadisp.show_document?p_table=STANDARDS&p_id=10076

OSHA (1996). Occupational Safety and Health Guideline for Chlorine Dioxide. Retrieved 18th October 2008 from: <http://www.osha.gov/SLTC/healthguidelines/chlorinedioxide/recognition.html>

OSHA (1996). Occupational Safety and Health Guideline for Chlorine Dioxide. Retrieved 18th October 2008 from: <http://www.osha.gov/SLTC/healthguidelines/hydrogenperoxide/recognition.html>

National Cancer Institute (2004). Formaldehyde and Cancer: Questions and Answers. Retrieved 18th October 2008 from: <http://www.cancer.gov/cancertopics/factsheet/Risk/formaldehyde>

Watling, D. *et al.* (2002). Theoretical Analysis of the Condensation of Hydrogen Peroxide Gas and Water Vapour as Used in Surface Decontamination. *PDA Journal of Pharmaceutical Science and Technology*, Vol. 56, 291-299.

Munro K, Lanser J, Flower R. (1999). A Comparative Study of Methods To Validate Formaldehyde Decontamination of Biological Safety Cabinets. *Applied and Environmental Microbiology* 1999; Vol. 65 No.2: 873-876.

NOAA (2003). Cameo Chemicals: Hydrogen Peroxide. Retrieved 18th October 2008 from: <http://cameochemicals.noaa.gov/chemical/5023>

Kruse, R. H *et al.* (1991). Biological Safety Cabinetry. *Clinical Microbiology Reviews*, Vol. 4 No. 2, 207-241.